

The new

# electric

Victory Sweeper



Call or visit our web site for additional information

866.50.SWEEP

866.507.9337

Keep asking  
we're listening



**VICTORY  
SWEEPERS INC.**  
WINNING TOGETHER

*4 common batteries replace gasoline  
Based on proven golf cart technology  
Simple one-switch, on/off operation  
9+ hrs run time per charge  
Super silent operation*



victorysweepers.com

## E 500 SPECIFICATIONS



Frame .....	2"x2"x 1/4" Wall Square Steel Tubing
Axle Capacity.....	2000 lbs
Tires.....	20.5 x 8-10
Payload.....	600 lbs
Paint .....	Powder Coated <i>(Black Frame w/ your choice of high visibility Blue or Green Body colors, Optional unpainted stainless steel also available)</i>
Hopper.....	16 gauge steel
Hopper Coating .....	Powder Coated inside & out
Hopper Capacity.....	1.5 cu yds (volumetric)
Motor .....	24v DC
Hydraulic Curb Broom .....	Width 22"
Overall Length .....	132"
Overall Width.....	82"/1,778mm <i>(includes curb broom)</i>
Overall Height.....	49"
Total Dry Weight .....	1398 lbs
Optional Dust Control .....	25 Gal, 12v DC
Warranty .....	One Year Limited

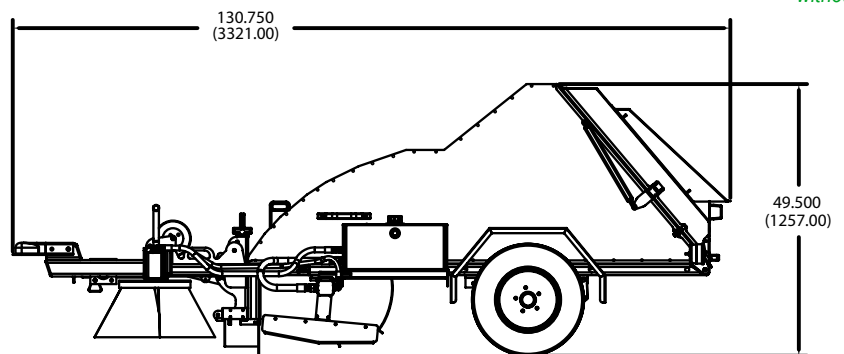
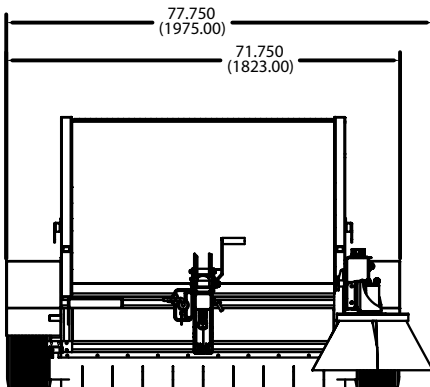

*\*Specifications subject to change without notice.*